

OMNIDEL

AUTOMATIC LOW-LEVEL SPLIT BINLIFT

The OmniDEL is an advanced, high quality automatic bin lift made by Terberg, built robustly and safe to operate, resembling the brand name of Terberg. The OmniDEL sets itself apart with its improved efficiency and extra safety enhancing features providing the best available low level bin lift.



REASONS TO CHOOSE THE OMNIDEL:

- The OmniDEL only weighs 595 kg.
- The OmniDEL is equipped with 4-wheel recognition, which means that it automatically switches when emptying 4-wheeled bins.
- The one-of-a-kind geometry of the OmniDEL guarantees that the operator does not need to take a step backwards during collection cycle, and it has a remarkable discharge angle of 50°.
- A single point greasing system is integrated in the standard equipment which contributes to shorter maintenance intervals.
- The OmniDEL has a unique ultrasonic anti spilling system. This system detects any material which might still be left in the bin, automatically shakes the load one time so that all remaining material is collected, and places the container back on the ground.
- The Rear Protective Device comes as standard and complies to safety norm EN 1501.5. This is active during automatic loading of the 2-wheeled containers.
- Shock and water resistant IP69K automotive parts, low-maintenance bearings, contactless sensors and switch elements offer perfect protection against the often heavy daily working conditions.
- The OmniDEL is designed in such a way that it can easily be provided with a dynamic weighing system and that it is prepared for the various identification systems.
- The OmniDEL is designed in such a way that it lifts the container with low speed at first, and speeds up afterwards. Ergonomically and in terms of working conditions, this is ideal because it minimises duty on wrists and shoulders.
- All electrical connections are 'plug and play', meaning that replacement of defect parts happens quickly and easily. A cleverly designed diagnosis system helps you with tracking down malfunctions and guarantees less standstill during maintenance.

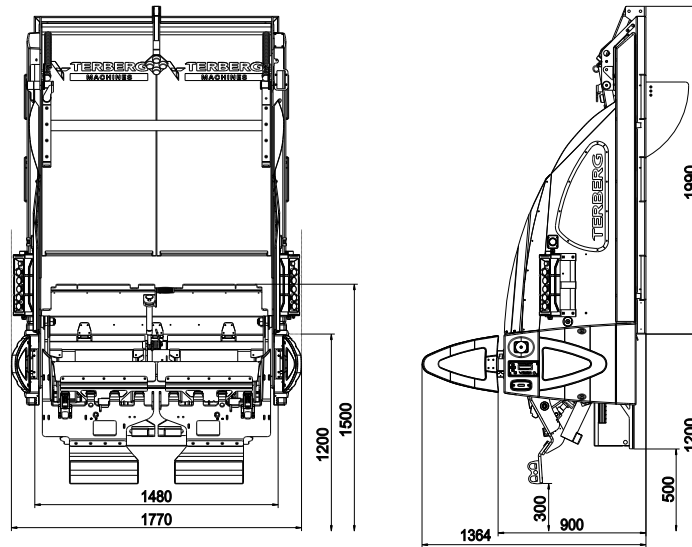

TECHNICAL SPECIFICATIONS



Bags & Bulky Waste



EN 840-1 80 -360 L

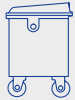

EN 840-2 500-1280 L



EN 840-3 770-1100 L

Chair configuration	Split twin chair	
Single Man Trade (SMT)	Standard	
Rear protection device (RPD)	Standard	
4-wheel container recognition	Standard	
Diagnostic display	Standard	
Sonar Switch / Mechanical Switch	Standard	Option
Sonar Sensor Anti-Spillage System	Standard	
Terberg Weighing & RFID preparation	Option	
CleAN Open CANbus output	Option	
Packer Cycle Delay Control (PCDC)	Option	
Lifting capacity	160kg (split) / 500kg (linked)	
Weight	595 kg	
Power source	Hydraulic	
Electrical connections	16-polige stekker / 24v	
Hydraulic connections	quick release couplings (DIN 2353, NW13, NW20)	
Hydraulic requirement	ideal 40 ltr/min., maximum 60 ltr/min., 180 bar	
Cycle time	2-wheel containers 6 - 7 sec. / 4-wiel 10-12 sec.	
Noise level	< 65 dB(A)	
Safety	CE machinery directive certification EN 1501-1 & EN 1505-5	



TERBERG ZENITH

19 Gul Crescent, Singapore 629528

T +65 6861 1100, E sales.tz.sg@terberg.com, I www.terbergzenith.com.sg

Terberg Environmental reserve the right to change the specification or design of our equipment at any time without prior notification.